

SECTION

NOTE:
 ECCENTRIC CONE TOP FOR MANHOLES OVER 8 FT. DEEP MAY BE USED IN LIEU OF FLAT CONCRETE COVER SLABS.

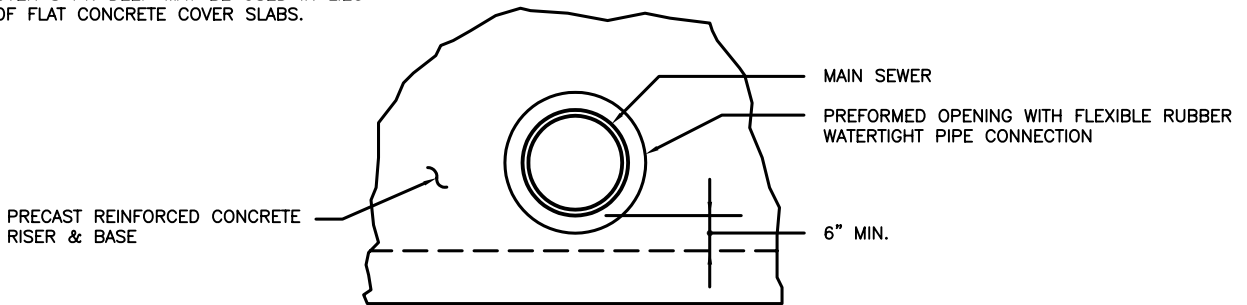

PREFORMED OPENING DETAIL

PRECAST CONCRETE MANHOLE

**SNIEDZE ASSOCIATES, CONSULTING ENGINEERS
 CANANDAIGUA, NEW YORK**

SCALE: 3/8" = 1'-0"

MAY 2007

SA-2